

Renewable energies: Photovoltaics

Making use of nature's power
safely and efficiently



Design the future
of energy



4 How energy generation has changed in the course of time

6 Protective measures and requirements of the applicable standards

9 Power supply system: IT system

10 Locating insulation faults - a challenge

12 Products for PV applications

15 Service and support



How energy generation has changed in the course of time

Developments in science and technology have always had a strong impact on the generation of energy. At first, hydropower turbines were used for power generation, and then the first fossil power plants came. In 1882 the first coal-fired power plant developed by Thomas Alva Edison started operation. This type of flexible and largely independent power generation was a milestone. As industrial processes progressed, decentralised generators based on combustion (e. g. of oil or gas) began to be used. In parallel to this, great efforts were expended to develop the generation of electricity with nuclear fuel elements. Later on, the first sustainable alternative was the generation and storage of renewable energies such as photovoltaics, wind energy, and hydrogen.

High availability of power-generation plants is a precondition for a stable and fail-safe power grid. High-quality components as well as an automated escalation management in the case of a fault provide the basis for this. Effective insulation monitoring, for instance, can notify of faults in an electrical installation early on. To permit the fastest possible location of a fault, such a device can additionally be combined with an automated error-detection system. In this manner fires due to insulation faults can be avoided, and power can be generated more safely. The Bender products and solutions for preventive analysis of an electrical installation's insulation level hence contribute to the fail-safe energy generation of the future.



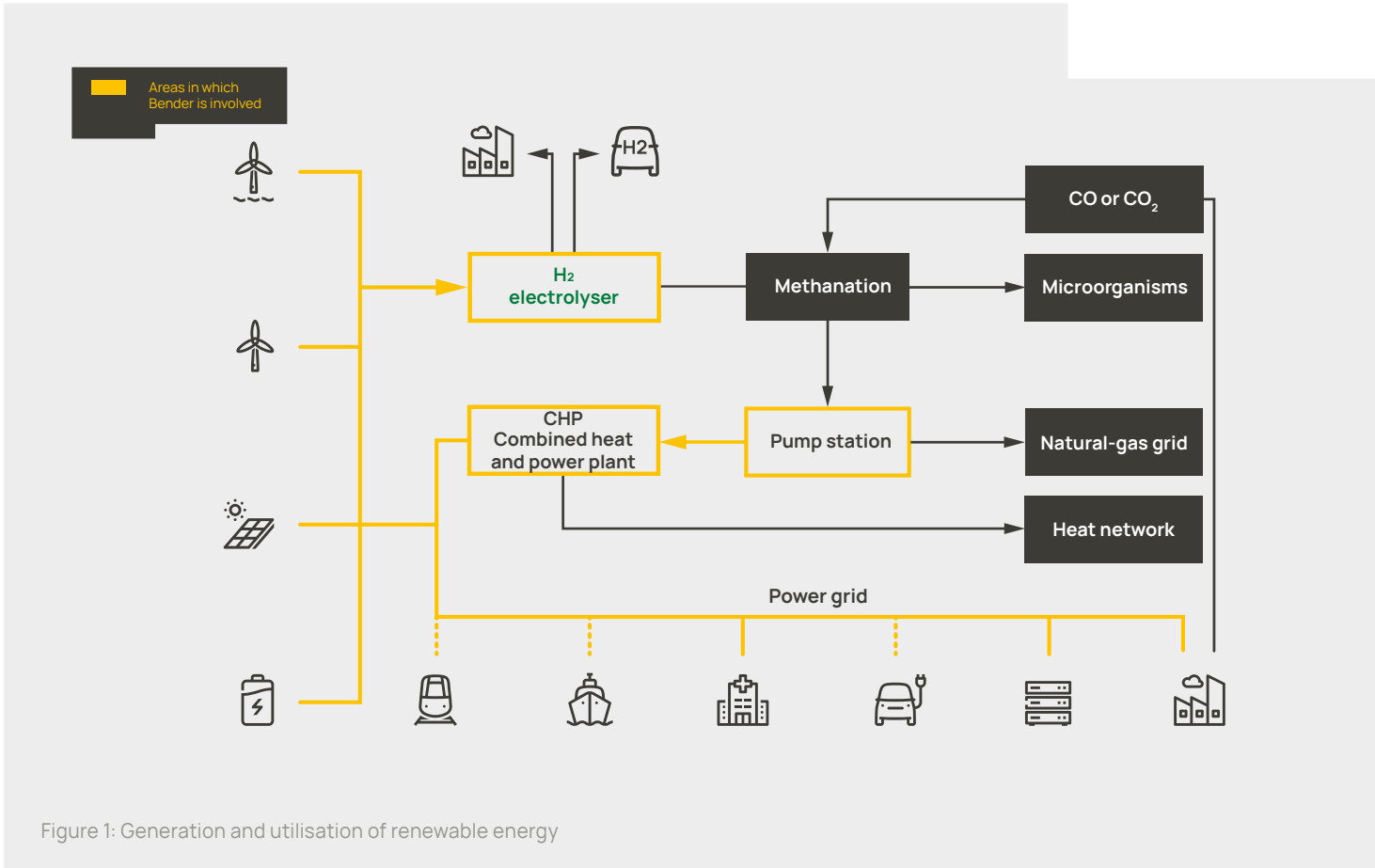
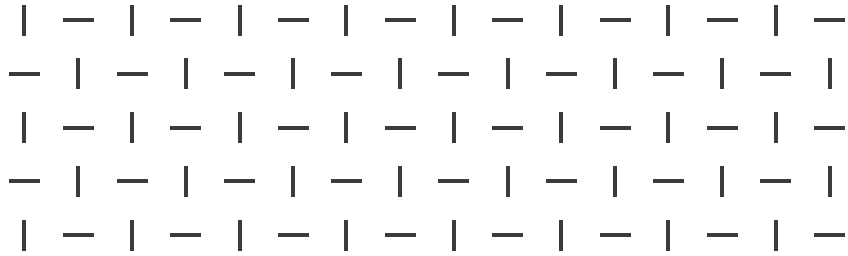

Figure 1: Generation and utilisation of renewable energy



Protective measures and requirements of the applicable standards

Since with photovoltaic installations the protective measure "automatic shutdown" cannot be employed, photovoltaic installations constitute a special case when it comes to electrical safety and the corresponding measures to be employed in case of an emergency. During the day the generators of the photovoltaic system generate energy continuously. They are de-energised practically only when it is dark. Hence the sole option remaining is a „double and reinforced insulation“ in accordance with part 412 of DIN VDE 0100-410 (IEC 60364-4-41) combined with continuous monitoring of the installation, for Part 412.1.2 stipulates, among other things, the following:

"Where this protective measure is to be used as the sole protective measure (i.e. where a whole installation or circuit is intended to consist entirely of equipment with double insulation or reinforced insulation), it shall be verified that effective measures, e.g. by adequate supervision [monitoring], will be in place so that no change can be made that would impair the effectiveness of the protective measure."

The modern insulation monitoring devices of the Bender ISOMETER® series can measure and visualise insulation resistance behaviour over time. This is necessary since there continue to be new findings about dangerous trouble spots (see figures 2 and 3) in connection with the installation and operation of PV systems, and this despite the extensive tests performed during the type approval of PV modules on the basis of the basic safety standards and the installation standard DIN VDE 0100-712 "Low voltage electrical installations – Part 7-712: Requirements for special installations or locations – Solar photovoltaic (PV) power supply systems." Metrological monitoring provides operators with an information edge before a critical condition will be reached (figure 4).



Figure 2: Burned wall socket due to corroded contacts



Figure 3: Destroyed insulation

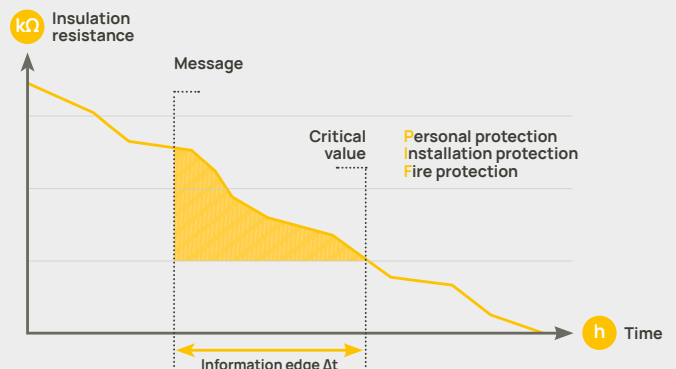
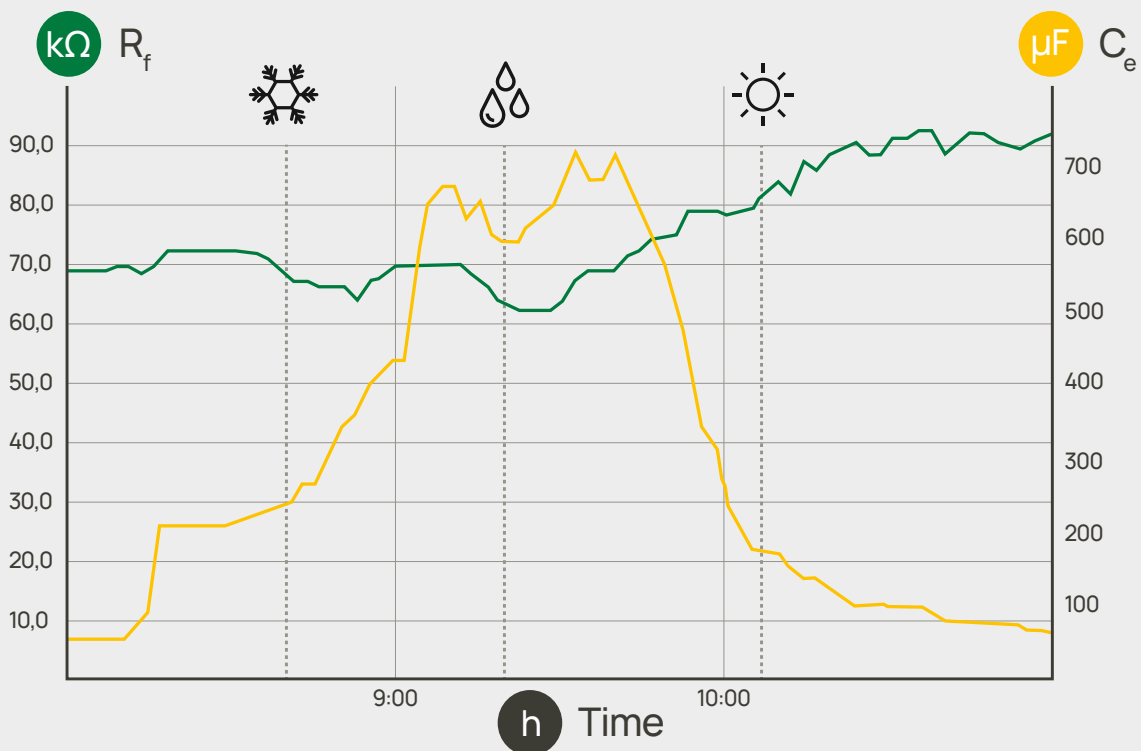

Figure 4: Change of insulation value



Practical example:

In a newly erected 15 MW solar power system consisting of several strings with 1.7 MW output each, morning humidity has resulted in a ten-fold increase in the system leakage capacitance C_e of the strings and a concomitant 30% reduction of the insulation resistance R_f . Considering that in future aging processes (material wear) will adversely affect the insulation value in addition, critical values can be reached very quickly.



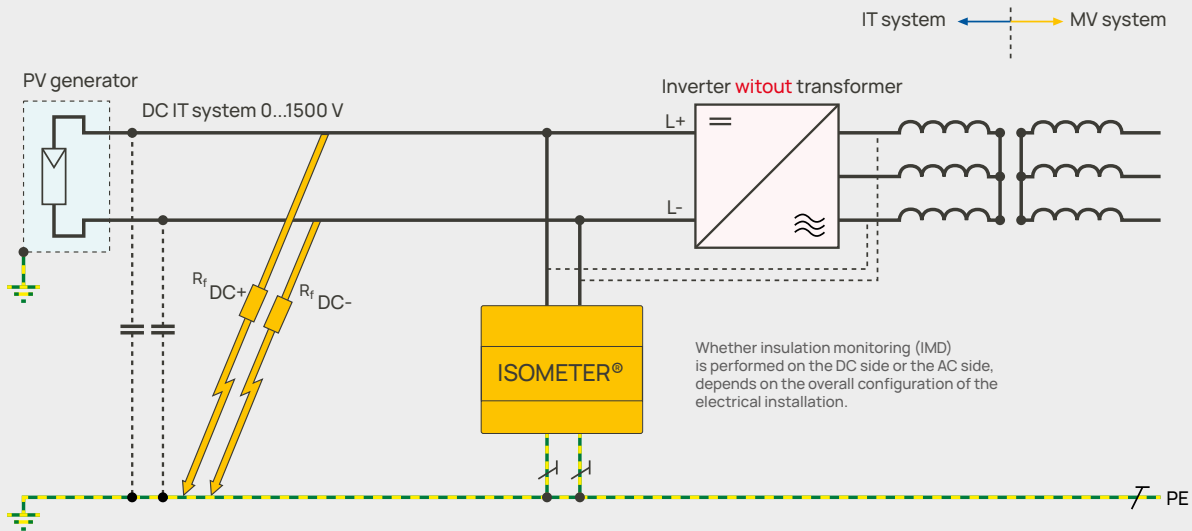

Figure 5: Inverter **without** transformer

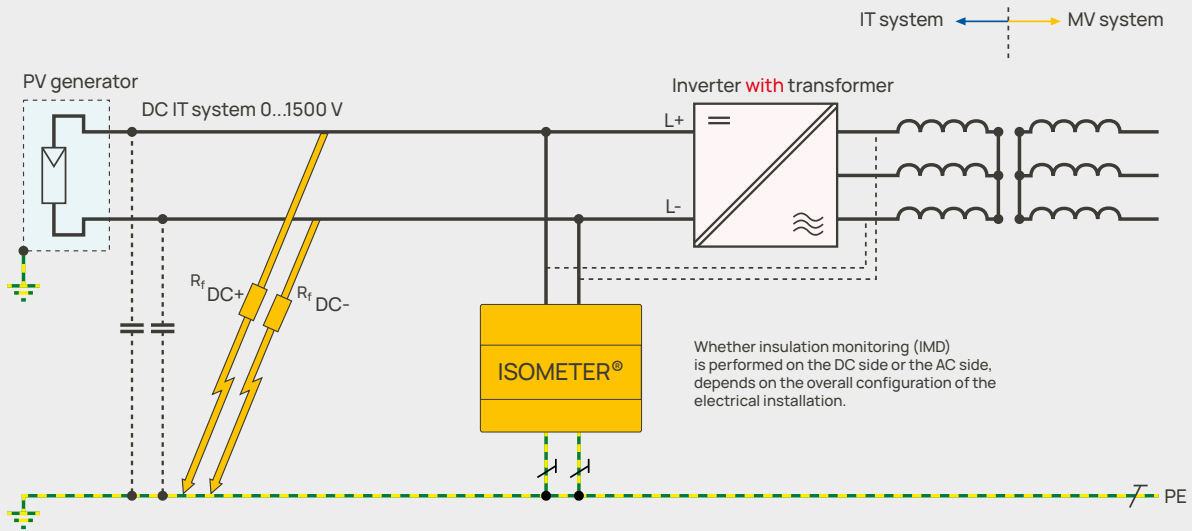

Figure 6: Inverter **with** transformer

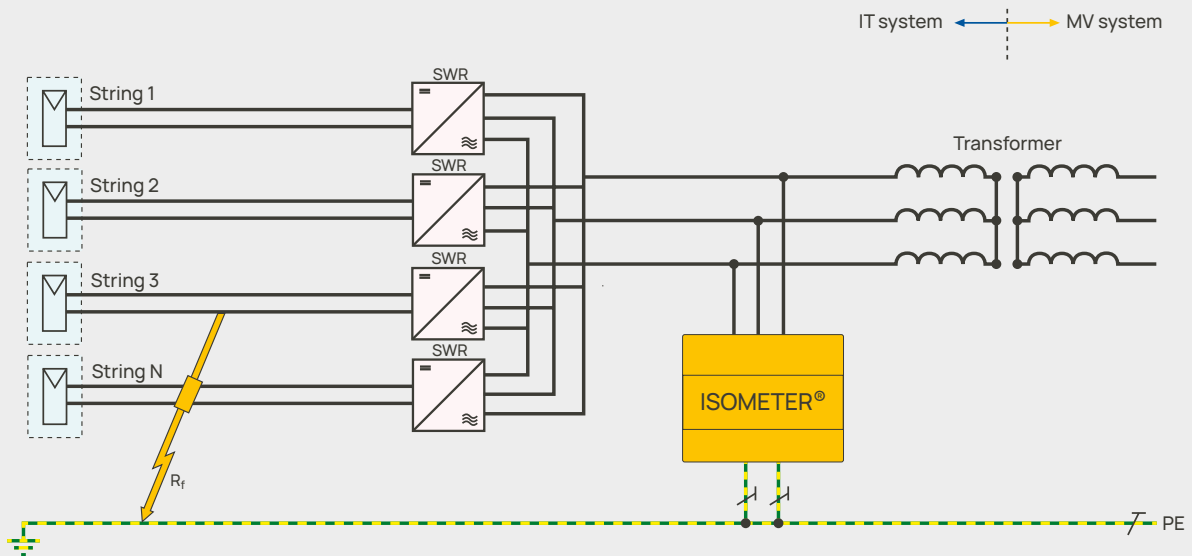

Figure 7: Decentralised string inverter (SWR)

Power supply system: IT system

The type of distribution system selected for photovoltaic installations is usually an IT system (Isolé Terre, no connection of the active conductors to earth). This provides the advantage of easier wiring and also higher availability since in IT systems a first fault need not lead to a shutdown or interruption. Extensive photovoltaic systems with an output of several megawatts [MW] are divided up into individual strings. These strings either have individual string inverters (figure 7) or they are connected to a central inverter (figure 8). In general, inverters are designed with or without a transformer, depending on their capacity and application (figures 5 and 6). When there is sufficient solar radiation, insulation is measured briefly within the string inverters, and only then the switch to "grid operation" is made. The IT system then comprises the solar panels up to the secondary winding of the transformer. During grid operation a central insulation monitoring device (IMD) as shown in figures 7 and 8 monitors the insulation level of the entire IT system.

PID - Potential induced degradation

The PID effect in PV modules with cristalline SI cells leads to a gradual decrease in output (degradation) which over time can become critical and significantly reduce yield. The known countermeasure, a potential increase of the PV generator after sunset, can be employed even when insulation is monitored centrally by means of an IMD, since then the inverter will no longer be in grid operation.

Complex measuring procedure

The current-carrying lines of the IT system act as a kind of capacitor with respect to the earth potential PE. The resulting system leakage capacitance C_e and the capacitive properties of the photovoltaic panel create a system leakage current which is decisively influenced by the overall surface [m²] and the humidity of the installation. The ISOMETER[®] insulation measuring devices by Bender use a patented measuring principle. To determine the insulation resistance R_f , they adapt to the design of the individual installation.

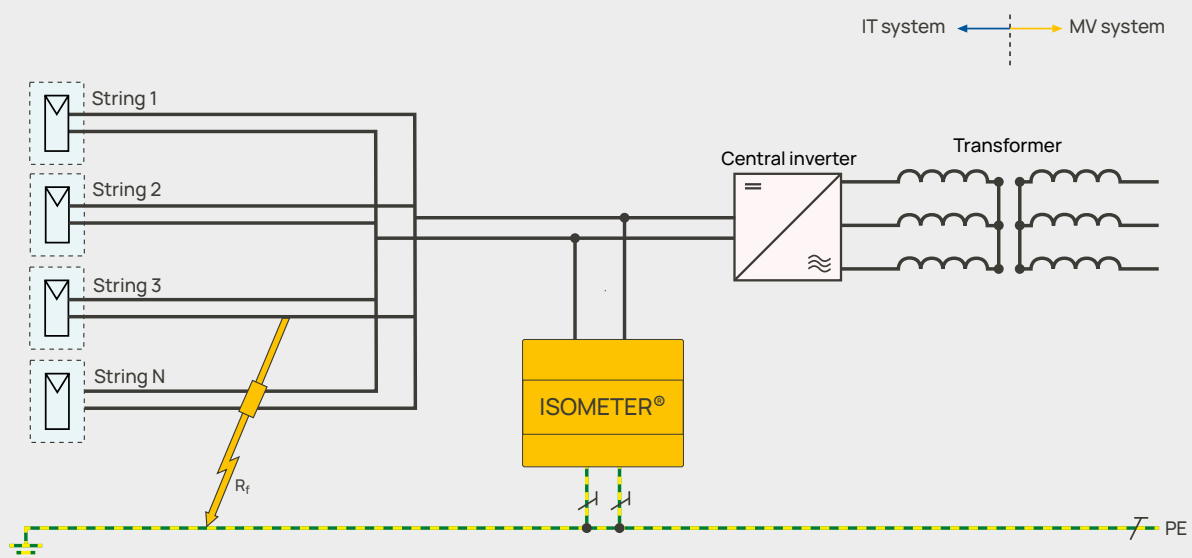

Figure 8: Central inverter (ZWR)

Locating insulation faults – a challenge

In the case of large-scale photovoltaic installations with an output of several megawatts [MW], the search for an arising insulation fault can prove to be difficult. By measuring the voltage in the individual strings, trained electricians can analyse the entire photovoltaic installation step by step and identify the affected string. Locating a fault within a string, however, most often requires separating the connections of interconnecting cables and unplugging plug-connections. This can lead to hazardous situations that are in conflict with the 5 safety rules of electrical engineering.

EDS – Earth Fault Detection System

An automated measuring method for the location of insulation faults (IFLS) can considerably increase the availability of the photovoltaic system. Automated fault location should be taken into account already during the planning stage. For this Bender offers the optimum solution. While the ISOMETER® monitors the insulation level of the solar power system with the AMP measurement method, detected insulation faults can be located rapidly with the device series ISOSCAN®. Corresponding transformers identify the affected string very quickly. With these Bender products your installation can hence achieve a high level of availability.

Sensor scaling

Apart from electrical safety aspects, return on investment (ROI) is also a focus for solar power systems. Bender therefore offers a cost-optimised fault location system in the form of current clamps (figures 9, 10, and 11). For the current clamps to be able to detect the locating current, the insulation monitoring device ISOMETER® needs to be furnished with an integrated locating current injector already when it is delivered from the factory (device designations ending in P). Should this not be the case, an ISOMETER® with locating current injector can be used for temporary fault location also subsequently. Due to the plug-in terminals this can be effected easily without violating the five safety rules.

The five safety rules:

- Disconnect completely
- Secure against re-connection
- Verify absence of operating voltage
- Carry out earthing and short-circuiting
- Provide protection against adjacent live parts



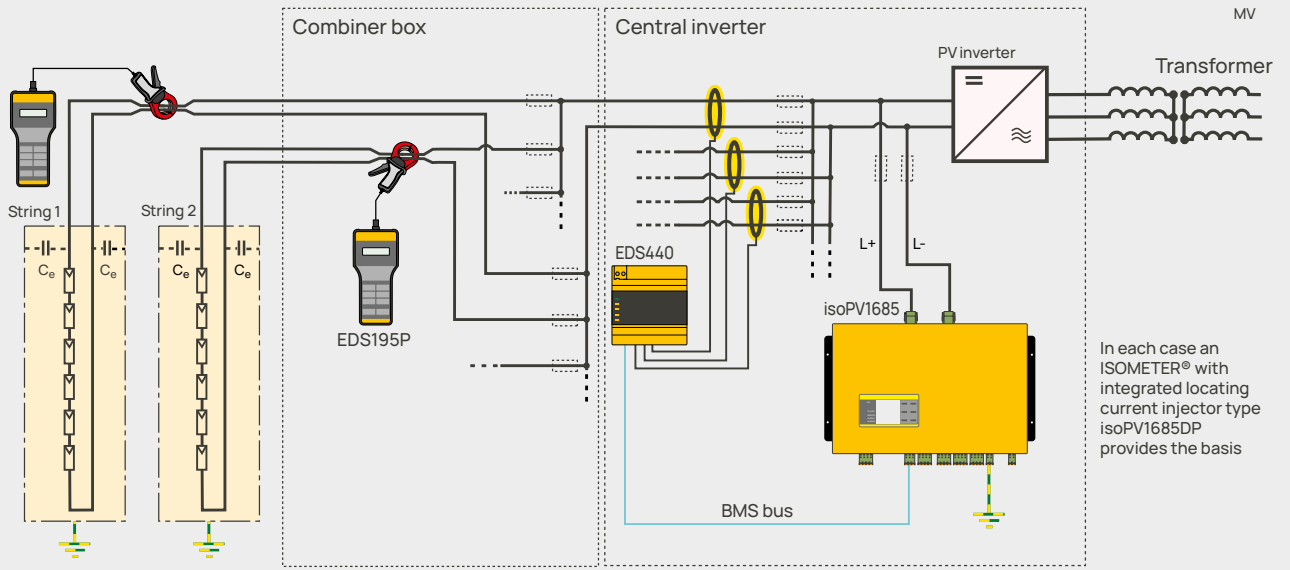

Figure 9: Insulation fault location using permanently installed current transformers and/or mobile current clamps.

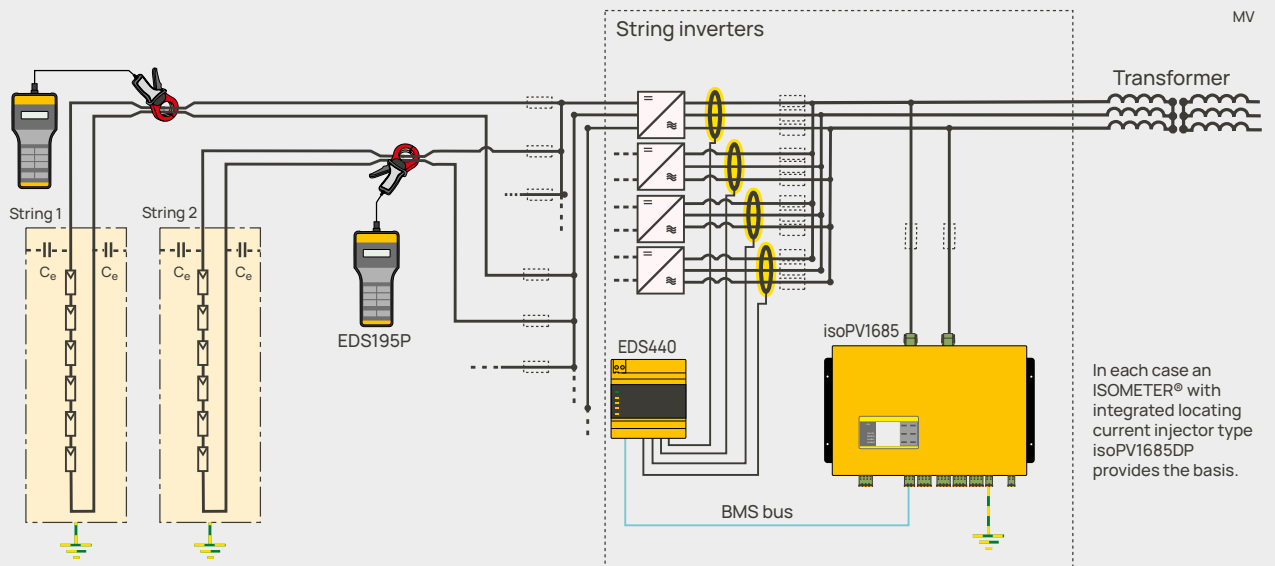
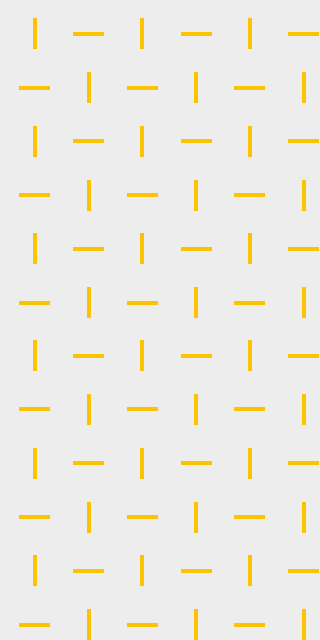

Figure 10: Insulation fault location using permanently installed current transformers and/or mobile current clamps.





Figure 11: Current clamp

Products for PV applications



ISOSCAN®

Product	 ISOSCAN® EDS440-L-4	 IOM441-S
Nominal system voltage U_N	AC 0...1000 V DC 0...1500 V	—
Supply voltage	AC/DC 24...240 V	DC 24 V
Number of measuring channels	12	—
Response value $I_{\Delta L}$	2...10 mA	—
Display	Status LEDs	Power-on LED
Modbus	—	—
BMS	✓	—
isoData	✓	—
Article number	B91080202	B95012057

Measuring current transformers for EDS440

	Inner diameter [mm]	Type	Article number
round	20	CTAC20	B98110005
	35	CTAC35	B98110007
	60	CTAC60	B98110017
	120	CTAC120	B98110019
	210	CTAC210	B98110020
	20x30	WS20x30	B98080601
split core	50x80	WS50x80	B98080603
	80x120	WS80x120	B98080606



EDS3090 / EDS195PM





PSA3020



PSA3052

Evaluation current $I_{\Delta L}$	0.2...50 mA	—	—
Response value $I_{\Delta N}$	0.2...1 or 2...10 mA	—	—
Display	3 x 16 characters	—	—
Diameter	—	20 mm	52 mm
Cable length	—	2 m	2 m
Article number	B91082026	B91082026	B91082026
Scope of supply	EDS195PM incl. PSA3020 + PSA3052	PSA3020 incl. EDS195PM + PSA3052	PSA3052 incl. EDS195PM + PSA3020

ISOMETER®

Product	 <p>ISOMETER® isoPV425 + AGH420</p>	 <p>ISOMETER® isoPV1685RTU</p>	 <p>ISOMETER® isoPV1685DP</p>
Mains voltage	AC 0...690 V DC 0...1000 V	AC 0...1000 V DC 0...1500 V	AC 0...1000 V DC 0...1500 V
Supply voltage	AC 100...240 V DC 24...240 V	DC 24 V	DC 24 V
System leakage capacitance C_e	$\leq 500 \mu\text{F}$ (with $\geq 300 \text{ k}\Omega$) $\leq 1000 \mu\text{F}$ (with $\leq 300 \text{ k}\Omega$)	$\leq 2000 \mu\text{F}$	$\leq 4000 \mu\text{F}$
Response value R	1...990 k Ω	0.2...990 k Ω	0.2...990 k Ω
Display	✓	Status LEDs	✓
Locating current injector	—	—	Locating current injector
Modbus	RTU	RTU	RTU
BMS	✓	✓	✓
isoData	✓	✓	✓
Article number	B9036303	B91065603	B91065808



Competent service for maximum safety and high availability of your installation

Service and support

Comprehensive service for your installation

Owing to many years of experience gained in difficult industrial environments and based on many customised adaptations of our measuring equipment, Bender has the knowledge and expertise needed to meet the special challenges of the photovoltaic sector.

From the initial consultation with our sales department to the processing of orders and the installation, our experienced specialists are ready to support you with all their expertise and are always glad to advise you.

Upon request we perform comparison measurements on site so as to optimise the parameter settings of your photovoltaic system and to define suitable threshold values together with you.

Of course we also offer a **repair service for all our devices** and can carry out a device test or calibration when necessary.



Customer Service Center First level support

Technical support by phone or e-mail for all Bender products

Tel.: +49 6401 807-760
E-mail: support@bender.de



Customer Service Center Repair service

Repair service for all Bender products

Tel.: +49 6401 807-741
E-mail: repair@bender.de



Customer Service Center Field service

On-site service for all Bender products

Tel.: +49 6401 807-744
E-mail: fieldservice@bender.de

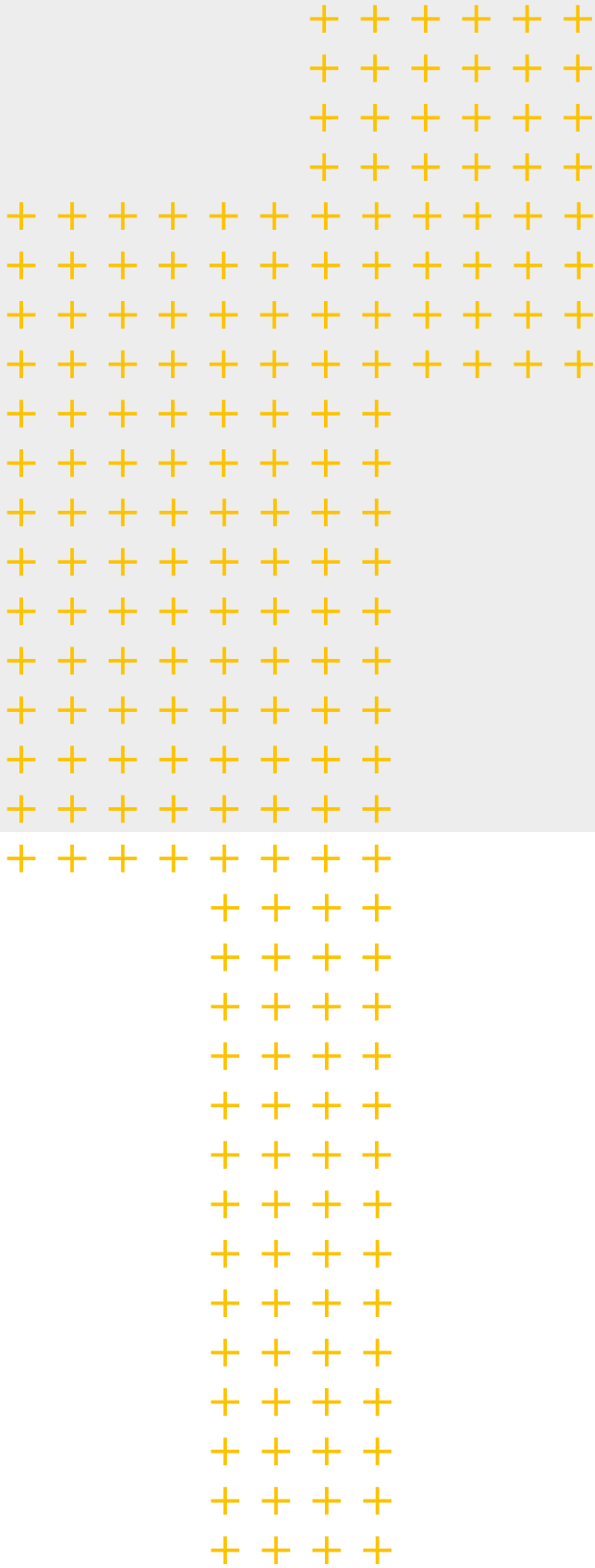

Bender GmbH & Co. KG

Londorfer Straße 65
35305 Grünberg
Germany

Tel.: +49 6401 807-0
info@bender.de
www.bender.de

Fotos: AdobeStock (@lovelyday12, @ABCdstock, @Kitreel, @Kampan, @Clayton D - peopleimages.com), photovoltaikbuero Ternus & Diehl GbR, and Bender archives.

2236de / 06.2023 / © Bender GmbH & Co. KG, Germany - subject to change! The specified standards take into account the version that was valid at the time of printing.

